

# Damage Evaluation in Concrete Structures Due to Earthquake by AE Rate-Process Analysis

Ninel ALVER \*, Mustafa KARCILI \*, Emre ERCAN \*, Yuma KAWASAKI \*\*,  
Masayasu OHTSU \*\*\*

\* Ege University, Department of Civil Engineering, Bornova, Izmir, Turkey

\*\* Ritsumeikan University, Department of Civil Engineering, Shiga, Japan

\*\*\* Kumamoto University, Graduate School of Science and Technology,  
Kurokami, Kumamoto, Japan

**Abstract.** Investigation of the condition of concrete structures in earthquake active zones has vital importance before and after the earthquake to decide whether the structure should continue its service or not. The durability and stability of concrete structures are affected by the environmental conditions such as salt and chemical attack, freezing and thawing, carbonation, alkali silica reaction, fatigue as well as dynamic loads such as earthquake. In order estimate the structural integrity, it is important to know the condition of the material used in the structure. In existing structures, mechanical damage of concrete has been estimated by evaluating the strength determined from the compression test. However, the degree of damage cannot be estimated only from the compressive strength. Thus, damage evaluation techniques for diagnosis are in great demand. Quantitative damage evaluation of structural concrete is made by applying acoustic emission (AE) and damage mechanics. Damaged concrete samples are examined based on fracturing behavior under unconfined compression. AE behavior of concrete under compression is dependent on the degree of damage and could be analyzed by rate-process analysis.

In this study, core samples were collected from concrete structures damaged by earthquake. Under compression test, compressive strengths and Young's moduli of these samples were measured along with AE measurements. After calculating Young's moduli of the intact concrete from the correlation of AE rate and damage parameter, the damage of concrete used in the structure is estimated.

## Introduction

In tectonically active regions such as Turkey, it is important to determine the damage level of a structure after it has been subjected to an earthquake to decide whether or not to use it. In order to diagnose the structure's condition, there are several methods applied. In general, after observing the structure, the mechanical tests are carried out to obtain mechanical properties of the materials. After conducting structural analyses with the new material properties and dimensions of the structural members, the condition of the structure is approached. This procedure takes long time and does not give information about the damage level of the materials in structural members.



Acoustic Emission (AE) method is known to be applicable for determining the degree of damage in concrete. It has been confirmed that AE rate process analysis can be applied for damage level identification in concrete structures subjected to freeze-thaw, carbonation etc. [1-5]. Thus, in order to investigate applicability of the method for damage and damage level detection within concrete structures due to earthquake, AE measurement was conducted during an unconfined compression test. 11 core samples were taken from the columns of a building damaged by 2011 Simav Earthquake in Turkey. Under compression test, compressive strengths and Young's moduli of these samples were measured along with AE measurements. After calculating Young's moduli of the intact concrete from the correlation of AE rate and damage parameter, the damage of concrete used in the structure was estimated.

## 2. AE Rate Process Analysis

AE activity of a concrete sample under compression is linked with the generation of micro-cracks. Until final failure, these cracks are increasingly accumulated. Besides this, the number of AE events increases due to accumulation of micro-cracks. Since AE behavior is associated with the number of micro-cracks at an apparent level, this process could be considered as stochastic. Therefore, the rate process theory was introduced to evaluate AE behavior under compression [1-5].

In Equation (1), the number of AE events due to the increment of stress from  $V$  to  $V+dV$ ,  $dN$ , is represented.

$$dN/N = f(V) dV. \quad (1)$$

where  $N$  is the total number of AE events and  $f(V)$  is the probability function of AE at stress level  $V(\%)$ . Then, the following function is introduced at Equation (2),

$$f(V) = a/V + b. \quad (2)$$

In Equation (2),  $a$  and  $b$  are empirical constants.  $a$ , rate value, represents the AE activity at a certain stress level. Two possible probability function is available depending on whether the rate " $a$ " is positive or negative. When the rate " $a$ " is positive, the probability of AE activity is high at a low stress level. This suggests that the concrete could be damaged. In the case of the rate " $a$ " is negative, probability of AE activity is low at a low stress level, implying the concrete is in sound state [1-5].

From Eqs. (1) and (2), a relationship between the number of accumulated AE events  $N$  and stress level  $V(\%)$  is represented as following,

$$N = CV^a \exp(bV). \quad (3)$$

In Equation (3),  $C$  is integration constant. Also,  $a, b$  and  $C$  are determined by the least square error analysis.

From damage mechanics concept, damage parameter  $\Omega$  is defined from a relative ratio of the modulus of elasticity [6],

$$\Omega = 1 - E/E^*. \quad (4)$$

where  $E$  is the modulus of elasticity and  $E^*$  is the modulus of the concrete which is assumed to be intact and undamaged.

In Equation (5), a relationship between damage parameter  $\Omega$  and strain  $\varepsilon$  under compression is represented by Loland [6],

$$\Omega = \Omega_0 + A_0 \varepsilon^\lambda . \quad (5)$$

where  $\Omega_0$  is the initial damage at the onset of the compression test, and  $A_0$  and  $\lambda$  are empirical constants. From Eqs (4) and (5), Eqs. (6) and (7) are derived,

$$\sigma = (E_0 - E^* A_0 \varepsilon^\lambda) \varepsilon . \quad (6)$$

$$E_0 = E^* (1 - \Omega_0) . \quad (7)$$

In order to estimate the initial damage  $\Omega_0$  in Eq. (7), it is fundamental to obtain the Young's modulus of intact concrete  $E^*$ . However, it is hard to estimate Young's modulus  $E^*$  from concrete in an existing structure. Therefore, it is attempted to estimate  $E^*$  from AE monitoring in the compression test.

A relationship between stress and strain is plotted in the uniaxial compression test of a concrete sample. With Eq. (4), it is proved that the initial Young's modulus  $E_0$  is associated with the initial damage  $\Omega_0$ .

Ohtsu confirmed a correlation between the decrease of the Young's modulus under unconfined compression,  $\log_e(E_0 - E_c)$  and the rate "a" derived from AE rate process analysis [4,5]. It is expressed that the increase in the damage corresponds to the decrease in Young's modulus ( $E_0 - E_c$ ), as in Eq. (8);

$$E_0 - E_c = E^*(1 - \Omega_0) - E^*(1 - \Omega_c) = E^*(\Omega_c - \Omega_0) . \quad (8)$$

Hence, a linear correlation between  $\log_e(E_0 - E_c)$  and the rate "a" value is expressed as,

$$\log_e(E_0 - E_c) = \log_e[E^*(\Omega_c - \Omega_0)] = Da + c . \quad (9)$$

In Eq. (9), it is assumed that  $E_0 = E^*$  when  $a=0$ . This assumption allows us to estimate Young's modulus of intact concrete  $E^*$  from AE rate-process analysis as,

$$E^* = E_c + \exp(c) . \quad (10)$$

### 3. Experimental Study

11 cylindrical core samples with diameter of 95 mm from columns of a damaged building by 2011 Simav Earthquake in Turkey were collected. In order to reduce AE events generated by friction, top and bottom of all samples were flattened and during the compression test teflon sheets were used. Unconfined compression test set-up is shown in Fig.1. MISTRAS-AE System was used as AE measuring device. In order to monitor AE activities of samples under compression, 2 UT-1000 AE sensors were employed. Silicon grease was pasted between the face of the sensor and samples in order to maintain perfect transmission. To count the number of AE hits, threshold level of the pre-amplifiers were set to 40 dB. It should be noted that AE measurement was conducted with two channels. The averaged values of two-channel measurement were analyzed.

Lateral and longitudinal strains were measured by using 4 strain gauges and the results were averaged.

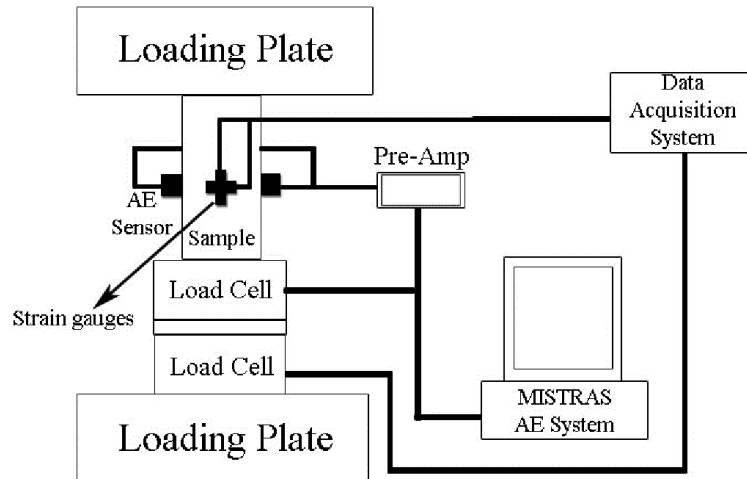

Fig. 1. Set-up for the uniaxial compression test and AE measurement system.

#### 4. Results and Discussion

Young's moduli of core samples,  $E_0$  and  $E_c$ , were determined from the compression test. Table 1 shows mechanical properties of all samples.

In data analysis, Young's modulus of intact concrete  $E^*$  was estimated by Eq. (10). The relative damage was determined with the ratio  $E_0/E^*$ , which is the ratio of the initial tangent Young's modulus to intact Young's modulus estimated.

In order to determine  $E^*$  from the relationship in Eq. (9), a large number of data are needed. The samples included in the database are all tested in previous studies, including the data of the present study. By using this database which is called the DeCAT system, Young's modulus of the normal concrete  $E^*$  and then the relative damage of specimens can be estimated [4,5].

Relative damages and compressive strengths of 11 core samples are shown in Table 1. Relative damage  $E_0/E^*$  varies from 0.55 to 1.56. Damages estimated in nine samples are below 1.0 which indicates that they are damaged. The compressive strengths of the samples are quite different from each other, since the concrete material of the building is hand-mixed concrete.

Table 1. Mechanical properties of core samples

No	$f'_c$ (MPa)	$E_0$ (GPa)	$E_c$ (GPa)	$E^*$ (GPa)	$E_0/E^*$
1	9.3	9.1	5.7	13.5	0.67
2	6.9	5.9	3.7	9.1	0.65
3	20.7	17.3	11.2	19.9	0.87
4	11.6	10.2	6.3	6.5	1.56
5	9.8	8.7	5.6	10.3	0.84
6	13.2	11.0	6.2	9.2	1.2
7	7.1	5.7	4.1	7.9	0.72
8	8.8	8.1	4.8	11.7	0.69
9	16.3	13.9	8.8	16.8	0.82
10	7.9	7.0	3.6	12.7	0.55
11	8.6	8.5	4.6	11.2	0.74
Max.	20.7	17.3	11.2	19.9	1.56
Min.	6.9	5.7	3.6	6.5	0.55
Ave.	10.9	9.6	5.9	11.7	0.85

## 5. Conclusion

Core samples taken from a reinforced concrete building damaged by earthquake were tested under unconfined compression test and AE rate process analysis was applied to evaluate damage level of the samples. By using DeCAT system, relative damages of the concrete samples were obtained.

Out of 11 samples, 9 samples were found to be damaged. Despite the small number of core samples taken from the structure, by using the database, Young's modulus of intact concrete could be calculated. Thus, it is confirmed that AE rate process analysis can be applied for damage evaluation in concrete structures.

## References

- [1] Ohtsu, M., 1992, Rate process analysis of acoustic emission activity in core test of concrete, In:Proc of JSCE No.442/V-16, pp. 211-217.
- [2] Ishibashi, A, Hidaka, E., Farahat, A. M. and Ohtsu, M., 1995. Deterioration Evaluation by AE in Concrete Samples, Proc. 6th Int. Conf. Structural Faults and Repair, Vol. 2, pp. 69-74.
- [3] Ohtsu, M. and Watanabe, H., 2001, Quantitative Damage Estimation of Concrete by Acoustic Emission, Construction and Building Materials, 15, pp. 217-224.
- [4] Suzuki, T., Ohtsu, M. and Shigeishi, M., 2007, Relative Damage Evaluation of Concrete In a Road Bridge by AE Rate-Process Analysis, Materials and Structures, 40, pp. 221-227.
- [5] Suzuki, T., Ohtsu, M., 2004, Quantitative Damage Evaluation of Structural Concrete by a Compression Test Based on AE Rate Process Analysis, Construction and Building Materials, 18, pp. 197-202.
- [6] Loland K.E., 1980, Continuous damage model for load – response estimation of concrete. Cement Concr Res 10, pp. 395–402.